

Driver Manual

FS-8705-46 Silent Knight Farenhyt Black Series FACP Serial Driver

APPLICABILITY & EFFECTIVITY

Effective for all systems manufactured after January 2023.



Driver Revision: 1.02
Document Revision: 2.E



fieldserver

MSA Safety
1000 Cranberry Woods Drive
Cranberry Township, PA 16066 USA
Website: www.MSAsafety.com

U.S. Support Information:
+1 408 964-4443
+1 800 727-4377
Email: smc-support@msasafety.com

EMEA Support Information:
+31 33 808 0590
Email: smc-support.emea@msasafety.com

Contents

1	Description.....	4
2	Hardware Connections	5
	2.1 Connecting the Farenhyt Module to the FieldServer.....	5
	2.2 Farenhyt Printer Port Configuration.....	6
3	Data Array Parameters.....	7
	3.1 Specific Names Must be Used	8
4	Client Side Configuration	9
	4.1 Client Side Connection Parameters	9
	4.2 Client Side Node Parameters	10
	4.3 Client Side Map Descriptor Parameters.....	10
	4.3.1 FieldServer Specific Map Descriptor Parameters.....	10
	4.3.2 Driver Related Map Descriptor Parameters	10
	4.4 Map Descriptor Example	11
5	Server Side Configuration	12
6	Useful Features	13
	6.1 How Data is Stored.....	13
	6.2 System Reset and Synch	13
	6.3 Managing System Even Strings	14
7	Reference	16
	7.1 Error Messages	16
	7.2 Driver Stats	17

1 Description

This serial driver connects via RS-232 to the printer port of a Farenhyt Series Black FACP.

The driver is capable of being linked with other FieldServer drivers to form regular FieldServer firmware that can be installed on QuickServer and other FieldServer gateways. Other drivers can access the Farenhyt FACP data and serve using other protocols such as BACnet and Modbus. Over 120 protocols are supported. Any can be linked.

The driver is a passive client driver. It does not poll for data. It waits passively for the panel to transmit data. When an event is sent to the gateway it evaluates the event and turns data points on/off. These points are mapped onto BACnet / Modbus etc. objects so the BMS can read them.

The driver cannot be used to simulate a Farenhyt FACP, because only the passive client side of the protocol is implemented.

NOTE: How this driver stores data and how to manage system events are described in Section 6.1.

Fire Panels Supported by the Driver	
FACP Model Number	Compatibility
IFP-2100 (110VAC) IFP-2100HV (220VAC) Fire Alarm Panel with 2100 point capacity	Yes
IFP-2100ECS (110VAC) IFP-2100ECSHV (220VAC) Fire Alarm & Voice Panel with 2100 point capacity	Yes
IFP-300 – Fire Alarm Panel with 300 point capacity	Yes
IFP-300ECS – Fire Alarm & Voice Panel with 300 point capacity	Yes
IFP-75 – Fire Alarm Panel with 75 point capacity	Yes

Max Nodes Supported		
FieldServer Mode	Nodes	Comments
Passive Client	Many	Normally at a site the FACP's are connected together and the gateway is connected to the printer port of Panel 1

2 Hardware Connections

2.1 Connecting the Farenhyt Module to the FieldServer

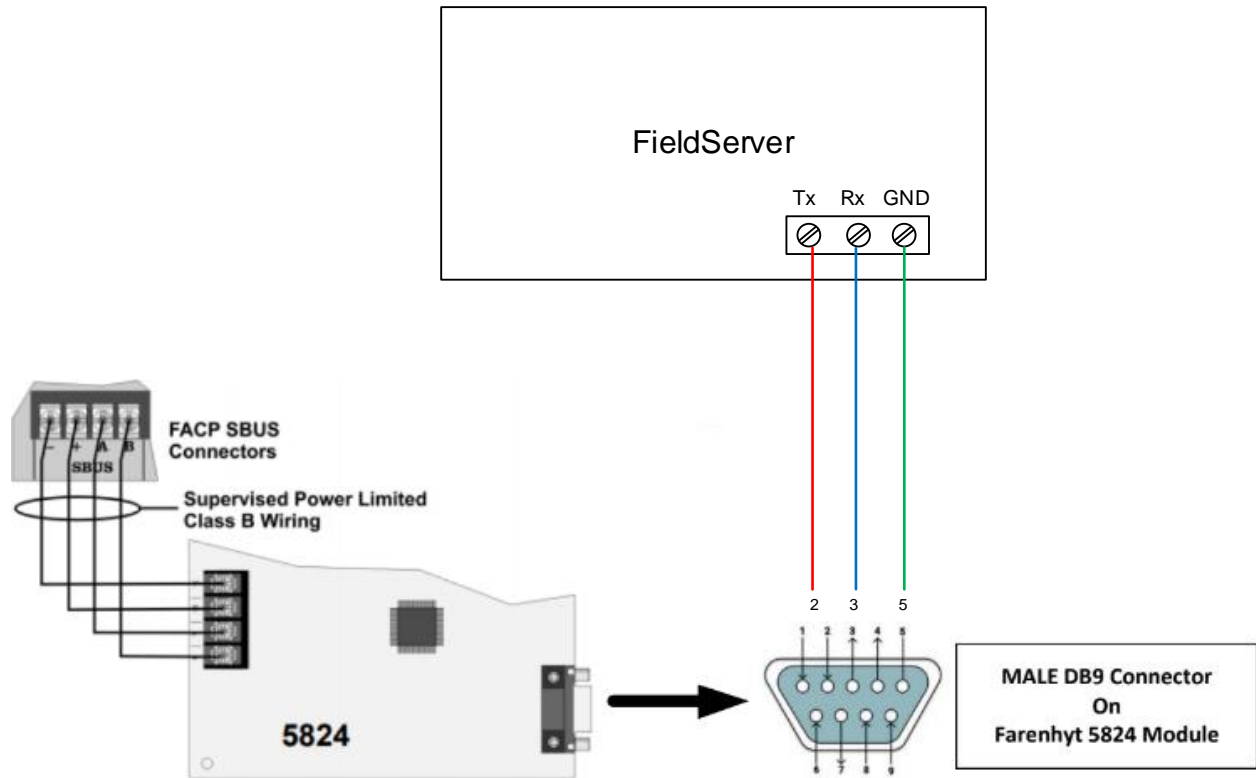

2.2 Farenhyt Printer Port Configuration

Select RS-232 in the FACP configuration and set the baud etc.

We use HFSS (Honeywell Fire Software Suite) and please see screenshot below. You will click on the 5824 Serial/Parallel Gateway in the config and select “Edit SBUS Module...” which will bring up this screen.

Edit SBUS Module

Module ID:

Module Type: 5824-Serial/Parallel/IO

Module Name:

Supervise Parallel/Serial Port

Enable Event Logging

[-] Network

- Site 1
- Site 2

Printer Port Selection

Parallel Port

Serial Port

Serial Port Options

Baud Rate:

Data Bits:

Stop Bits:

Parity:

3 Data Array Parameters

Data Arrays are “protocol neutral” data buffers for storage of data to be passed between protocols. It is necessary to declare the data format of each of the Data Arrays to facilitate correct storage of the relevant data.

Section Title		
Data_Arrays		
Column Title	Function	Legal Values
Data_Array_Name	Provide name for Data Array.	Up to 15 alphanumeric characters
Data_Array_Format	Provide data format. Each Data Array can only take on one format.	Recommended: FLOAT Float, Bit, Byte, Uint16, Uint32, Sint16, Sint32
Data_Array_Length	Number of Data Objects. Must be larger than the data storage area required by the Map Descriptors for the data being placed in this array.	1-10000

Example

```
// Data Arrays
Data_Arrays
Data_Array_Name , Data_Array_Format , Data_Array_Length
DA_AI_01 , Uint16, , 200
DA_AO_01 , Uint16 , 200
DA_DI_01 , Bit , 200
DA_DO_01 , Bit , 200
```

3.1 Specific Names Must be Used

This driver stores data in Data Arrays with specific names. If they are not found, then the relevant data is discarded. An error message is displayed.

The following Data Arrays should be created:

Name	Type	Length
P1M97FHYTmods	UINT16	200
P1M97FHYTsens	UINT16	200
PxMyyFHYTmods		
PxMyyFHYTsens		
Panel x		
Loop yy		
PHYTzones	UINT16	200
PHYTsys	UINT16	200
PHYTstats	UINT16	200

Repeat these 2 for each FACP panel networked to Panel 1.
 One pair of these DA's for each Loop in the system.
 E.g. M97 e.g. M01

4 Client Side Configuration

For detailed information on FieldServer configuration, refer to the FieldServer Configuration Manual. The information that follows describes how to expand upon the factory defaults provided in the configuration files included with the FieldServer (see “.csv” sample files provided with the FieldServer).

This section documents and describes the parameters necessary for configuring the FieldServer to communicate with Farenhyt FACP.

The configuration file tells the FieldServer about its interfaces, and the routing of data required. In order to enable the FieldServer for Farenhyt FACP communications, the driver independent FieldServer buffers need to be declared in the “Data Arrays” section, the destination device addresses need to be declared in the “Client Side Nodes” section, and the data required from the Servers needs to be mapped in the “Client Side Map Descriptors” section. Details on how to do this can be found below.

NOTE: In the following tables, * indicates an optional parameter and bold legal values are default.

4.1 Client Side Connection Parameters

Section Title		
Connections		
Column Title	Function	Legal Values
Port	Specify which port the device is connected to the FieldServer.	P1-P2, R1-R2 ¹
Protocol	Specify protocol used.	FARENHYT
Baud*	Specify baud rate.	110; 300; 600; 1200; 2400; 4800; 9600 ; 19200; 28800; 38400; 57600 Baud
Parity*	Specify parity.	Odd, Even, None
Data_Bits*	Specify data Bits.	7,8
Stop_Bits*	Specify stop Bits.	1, 2

Example

```
// Client Side Connections
Connections
Port          , Protocol      , Baud   , Parity  , Data_Bits , Stop_Bits
R1            , FARENHYT   , 9600   , None    , 8         , 1
```

¹ Not all ports shown are necessarily supported by the hardware. Consult the appropriate Instruction manual for details of the ports available on specific hardware.

4.2 Client Side Node Parameters

Section Title		
Nodes		
Column Title	Function	Legal Values
Node_Name	Provide name for Node.	Up 12 of the max of 32 alphanumeric characters possible to specify the Node name.
Node_ID*	Not used directly by the driver.	1-255
Protocol	Specify protocol used.	FARENHYT

Example

```
// Client Side Nodes
Nodes
Node_Name , Node_ID , Protocol
FACP , 1 , FARENHYT
```

4.3 Client Side Map Descriptor Parameters

4.3.1 FieldServer Specific Map Descriptor Parameters

Column Title	Function	Legal Values
Map_Descriptor_Name	Name of this Map Descriptor.	Up to 32 alphanumeric characters
Data_Array_Name	Name of Data Array where data is to be stored in the FieldServer.	One of the Data Array names from Section 3
Data_Array_Offset	Starting location in Data Array.	0 to (Data_Array_Length -1) as specified in Section 3
Function	Function of Client Map Descriptor.	Passive (waits for incoming message)

4.3.2 Driver Related Map Descriptor Parameters

Column Title	Function	Legal Values
Node_Name	Name of Node to fetch data from.	One of the Node names specified in Section 4.2
Data_Type	This commonly used parameter is not used.	
Length	This commonly used parameter is not used.	Set to 1
Address	This commonly used parameter is not used.	

4.4 Map Descriptor Example

In this example the current count record will be retrieved. If there is no record to retrieve then the DA_Data[1] will be set to zero, else to 1. 14 data values are extracted and stored in consecutive locations in the Data Array. See **Section 6.1** for a listing of what data you will find at each offset.

Map_Descriptor_Name	Data_Array_Name	Data_Array_Offset	Function	Node_Name	Length
CatchAll	, DA_Data	, 0	, Passive	, FACP	, 1

In the above example:

- Map_Descriptor_Name – Descriptive only. Not used.
- Data_Array_Name & Data_Array_Offset – The name of the Data Array in which the driver will store the data. **This Data Array is not actually used by the driver. Rather, data is stored in specially named Data Arrays.** The name must correspond to a Data Array defined in **Section 3**.
- Function – Driver waits passively.
- Node_Name – The Node as defined in **Section 4.2**. The Node Name connects the Map Descriptor to a Node which in turn connects the Map Descriptor to a port.
- Length – Reserve space in the Data Array.

5 Server Side Configuration

This driver cannot be used to emulate a FARENHYT FACP Counter. For some protocols we implement the client and server sides – like Modbus. In such cases the protocol can be used to emulate a device. We do not normally do this for protocols where we expect our customer will always want the Client functionality. Ask our sales department if you need to emulate a device.

6 Useful Features

6.1 How Data is Stored

Data is stored in Data Arrays with special names. See **Section 3**.

When a Module is in alarm – Its corresponding point in the Module Data array will be set to 1. This is the same for Sensors and Zones.

See examples titled with bold text below.

Receive this MODULE message

Manual Pull Alarm Zone 001 [M97:M0003]

Data Array set as follows: P1_Fhyt_Module [3] = 1

Receive this MODULE message

Manual Pull Alarm Restore Zone 001 [M97:M0003]

Data Array set as follows: P1_Fhyt_Module [3] = 0

Receive this SENSOR message

Manual Pull Alarm Zone 001 [M97:S0011]

Data Array set as follows: P1_Fhyt_Sensors [11] = 1

Receive this ZONE message

Manual Pull Alarm Zone 009

Data Array set as follows: P1_Fhyt_zones [9] = 1

Receive this SYSTEM message

System Power Up

Data Array set as follows: P1_Fhyt_sys [x] = 1

Find the Value of x in **Section 6.2**.

6.2 System Reset and Synch

When a System Reset message is received, the driver will set all the data in the associated data arrays to zero.

To Synch the gateway to the FACP – Connect gateway power to FACP power so they boot at the same time.

Push System Reset – All Active items will re-announce themselves. However, we recommend the synch be done, when there are no off-normal states in the FACP.

6.3 Managing System Even Strings

A file called sysstring.ini is provided and installed with the driver.

If it is absent, then an error will be reported.

If absent, then system messages will cause many errors and will result in system data points not being active.

At startup the file is read. This is how the driver learns the text of the Panel System Events.

The file is a simple CSV test file. It must contain at least 4 columns.

The System String file may be edited – suggested only to add or change. Be careful the format must be preserved.

When the file is processed the diver creates a file called “syststring.txt”. It contains a copy of the strings that were processed. It is provided for support and checking reasons. It is not used. File may be uploaded on the gateway – File Transfer – General Files Tab of the web interface.

IMPORTANT – It is important to the correct operation of the driver that in sysstring.ini a longer string must follow the shorter one for each pair

Emergency System Overridden

Emergency System Overridden Restore

Correct order. This has to do with comparing the strings in the tables to the event string in the message.

In the following table:

Column 1 = IndexNumber. Number is used in the following way. When a system event occurs, the driver takes the event text (string) and find the corresponding entry in the table. This number is then used as an offset into the Data Array called P1_Fhyt_Sys.

A pair of strings must be allocated the same IndexNumber since it's the same event.

E.g.

Emergency System Overridden

Emergency System Overridden Restore

Column 2 = DoSystem Reset. This is how the System Reset message is identified. When a message with a '1' In this column is received, the driver will do a system reset.

Column 3 = Is this an activation (off normal) or a restore. Does this message turn the point on or off.

E.g.

Emergency System Overridden

Emergency System Overridden Restore

Allocate a '1' to turn point on to indicate off-normal

Allocate a '0' to turn point off to indicate normal

Column 4 = String. This is the string the printer produces.

Column 5 etc = Ignored.

Some System Events can only turn On.

There is no restore for them. Only a system reset will turn the point off.

E.g. System Power Up

Multiple Panels

Driver supports networked FACP's.

Driver can only connect to Panel 1's printer port.

All networked panel events must be vectored to this port.

The driver assumes the default panel is 1.

If there is only one panel, then the data arrays for the other panels may be removed.

7 Reference

7.1 Error Messages

NOTE: If the message directs you to contact tech support and provide them with a log file then you should capture a full diagnostic.

Error Messages – We have shown place holders for the parts of the message which change.

%s is a place holder for a text string.

%d is a place holder for a number

%c is a place holder for an alpha character.

Explanation – messages are informational and do not require a corrective action. Simply use them to confirm configuration / behaviors are what you expect.

Message	Explanation
FHYT01 FYI System Reset Action	Printed whenever a System Reset is received. It clears all the data in the arrays used by the driver.
FHYT02 Err Cant recognize event=<%s>	Report to Tech Support*
FHYT03 FYI Creating file=%s	This message is part of the auto configuration system.
FHYT04 Max %d System Messages	The file sysstring.ini is being loaded. It contains system message strings. There are too many to load. The maximum amount permitted is shown in the message. Possibly the file is corrupt, out of date. Possibly there are more strings than that version of firmware will permit. If you cannot resolve this then report to Tech Support.
FHYT05 FYI Sys Message Not Found. <%s>	An event reported to the printer port contained a system event whose wording is not recognized. The event string is shown with the error message. We expect you should not see this message. If you do this then report to Tech Support. Possibly need a firmware update as this problem indicates a mismatch between the driver and the panel. Possibly sysstring.ini is corrupt or did not load properly. When system strings are loaded a file called sysstring.txt is created. It contains all the system strings that have been loaded from sysstring.ini. You can retrieve and inspect the txt file. Possibly an older version of sysstring.ini is being used. Possibly corrupt. Possible that sysstring.ini is not present. Use the file transfer (general tab) to retrieve the file – see if the process reports that the file could not be found.
FHYT06 FYI Autoconfig based on CDR file=%s	Ignore.

Message	Explanation
FHYT07 Err Cannot identify the panel number. Assume=1	Ignore if you only have one panel numbered as panel 1. This message is printed when the panel number cannot be extracted from the event. Probably because it is not present in the message. You should not see this error. Report to Tech Support.
FHYT08 Err Actionword=<%s> unknown.	This message is printed when an event is received but which is being ignored because the driver cannot tell if it is an alarm, trouble etc. You should not see this error. Report to Tech Support.
FHYT09 Err Store Failed DA with name=%s rqd.	You can try and resolve this yourself. It is printed when the driver parses an event but cannot find a place to store the event data. Event data is stored in Data Arrays. They have special names (see the data array section). Let's say you don't have an array called P1_FHYT_SYS then there is nowhere to store system event (e.g. battery low) for panel 1. If you cannot resolve this then report to Tech Support.
FHYT10 Err Cant recognize action word for zone <%s>.	You should not see this error. Report to Tech Support.
FHYT11 Err Store: Failed DA with name=%s rqd.	See FHYT09.
FHYT12	See FHYT10.

7.2 Driver Stats

This driver does not expose any operational stats. Most drivers do.