

Driver Manual

FS-8704-03 Modbus TCP/IP

APPLICABILITY & EFFECTIVITY

Effective for all systems manufactured after July 2022.



Driver Revision: 1.12
Document Revision: 5.C



fieldserver

MSA Safety
1000 Cranberry Woods Drive
Cranberry Township, PA 16066 USA
Website: www.MSAafety.com

U.S. Support Information:
+1 408 964-4443
+1 800 727-4377
Email: smc-support@msasafety.com

EMEA Support Information:
+31 33 808 0590
Email: smc-support.emea@msasafety.com

Contents

1	Description	4
2	Driver Scope of Supply	4
	2.1 Supplied by MSA Safety	4
	2.2 Provided by the Supplier of 3 rd Party Equipment	4
3	Hardware Connections	5
4	Data Array Parameters	6
5	Client Side Configuration	7
	5.1 Client Side Connection Parameters	7
	5.2 Client Side Node Parameters	8
	5.3 Client Side Map Descriptor Parameters	9
	5.3.1 FieldServer Specific Map Descriptor Parameters	9
	5.3.2 Driver Specific Map Descriptor Parameters	9
	5.3.3 Timing Parameters	10
	5.4 Map Descriptor Examples	10
6	Configuring the FieldServer as a Server	11
	6.1 Server Side Connection Parameters	11
	6.2 Server Side Node Parameters	12
	6.3 Server Side Map Descriptor Parameters	13
	6.3.1 FieldServer Specific Map Descriptor Parameters	13
	6.3.2 Driver Specific Map Descriptor Parameters	13
	6.4 Map Descriptor Examples	14
	6.4.1 Slave_ID	14
7	Useful Features	15
	7.1 Managing Floating Points with Modbus	15
	7.1.1 Transferring Non-integer Values with One Register	15
	7.1.2 Transferring Float/32 bit Values with Two Registers	16
	7.2 Node_Offline_Response	17
	7.3 Splitting Registers into Bytes or Bits	18
	7.4 Reading Data Types	18
	7.4.1 32-Bit Integer and Float Data Types	18
	7.4.2 Relinquishing Control of a Point as a Client	19
	7.4.3 64-Bit Integer and Float Data Types	20
	7.5 Reading Device Identification	21
	7.5.1 Client Side Map Descriptor	21
	7.5.2 Server Side Map Descriptor	21
	7.6 Broadcasting Write Messages	21
	7.7 Reading Scattered Addresses	22
8	Troubleshooting	23
	8.1 Server Configuration of System Station Address	23
	8.2 Modbus TCP/IP Connection Error Descriptions	23
	8.3 Understanding Max Concurrent Messages	23
9	Reference	25
	9.1 Data Types	25
	9.2 Single Writes	25
	9.3 Driver Error Messages	25

1 Description

The Modbus TCP Driver allows the FieldServer to transfer data to and from devices over Ethernet using the Modbus TCP/IP Protocol. The Modbus TCP/IP driver uses port 502, which is not configurable. The driver was developed for Modbus Application Protocol Specification V1.1a from Modbus-IDA. The specification can be found at www.modbus.org. The FieldServer can emulate either a Server or Client.

The information that follows describes how to expand upon the factory defaults provided in the configuration files included with the FieldServer.

There are various register mapping models being followed by various vendors.

To cover all these mappings, FieldServer uses the following three Models:

- **Modicon_5digit** – Use this format where addresses are defined in 0xxxx, 1xxxx, 3xxxx or 4xxxx format. A maximum of 9999 registers can be mapped of each type. This is FieldServer driver's default format.
- **ADU** – Application Data Unit address. Use this format where addresses of each type are defined in the range 1-65536.
- **PDU** – Protocol Data unit address. Use this format where addresses of each type are defined in the range 0-65535.

An example of the key difference between ADU and PDU:

- If Address_Type is ADU and address is 1, the driver will poll for register 0.
- If Address_Type is PDU, the driver will poll for address 1.

NOTE: If the vendor document shows addresses in extended Modicon (i.e. 6 digit) format like 4xxxxx then consider these addresses as xxxxx (omit the first digit) and use either ADU or PDU.

NOTE: The purpose of providing 3 different ways of addressing the Modbus registers is to allow the user to choose the addressing system most compatible with the address list being used. At the protocol level, the same protocol specification is used for all three with the exception of the limited address range for Modicon_5digit.

2 Driver Scope of Supply

2.1 Supplied by MSA Safety

Part #	Description
FS-8915-10	UTP cable (7 foot) for Ethernet connection ¹

2.2 Provided by the Supplier of 3rd Party Equipment

Description
Modbus/TCP Server, e.g. Quantum PLC ²
Modbus/TCP Host Node [such as: Intellution Fix, Wonderware Intouch, GE Cimplicity, Quantum PLC (Master)] ³

¹ This cable is necessary for connection to the driver. It is shipped with the FieldServer and not separately with the driver.

² If FieldServer is used as a Modbus/TCP Client.

³ If FieldServer is used as a Modbus/TCP Server.

3 Hardware Connections

Configure the PLC according to manufacturer's instructions.

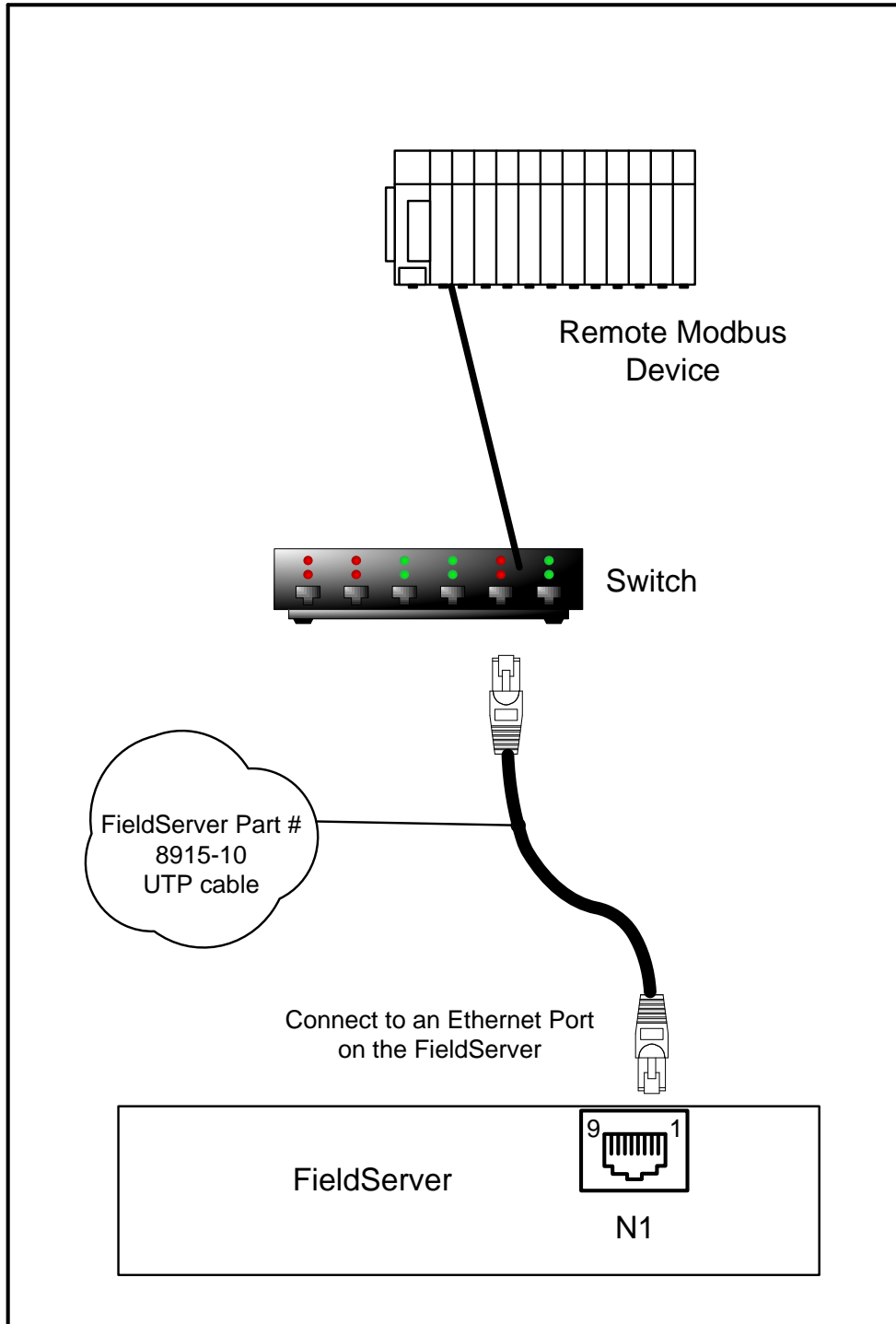

4 Data Array Parameters

Data Arrays are “protocol neutral” data buffers for storage of data to be passed between protocols. It is necessary to declare the data format of each of the Data Arrays to facilitate correct storage of the relevant data.

Section Title		
Data_Arrays		
Column Title	Function	Legal Values
Data_Array_Name	Provide name for Data Array.	Up to 15 alphanumeric characters
Data_Array_Format	Provide data format. Each Data Array can only take on one format.	Float, Bit, Byte, UInt16, UInt32, Sint16, Sint32
Data_Array_Length	Number of Data Objects. Must be larger than the data storage area required by the Map Descriptors for the data being placed in this array.	1 – 255

Example

```
// Data Arrays
Data_Arrays
Data_Array_Name , Data_Array_Format , Data_Array_Length
DA_AI_01 , UInt16, , 200
DA_AO_01 , UInt16 , , 200
DA_DI_01 , Bit , , 200
DA_DO_01 , Bit , , 200
```

5 Client Side Configuration

For detailed information on FieldServer configuration, refer to the FieldServer Configuration Manual. The information that follows describes how to expand upon the factory defaults provided in the configuration files included with the FieldServer (see “.csv” sample files provided with the FieldServer).

This section documents and describes the parameters necessary for configuring the FieldServer to communicate with a Modbus TCP/IP Server.

The configuration file tells the FieldServer about its interfaces, and the routing of data required. In order to enable the FieldServer for Modbus TCP/IP communications the following three actions must be taken. The driver independent FieldServer buffers need to be declared in the “Data Arrays” section. The destination device addresses need to be declared in the “Client Side Nodes” section. And the data required from the server(s) needs to be mapped in the “Client Side Map Descriptors” section. Details on how to perform these steps can be found in the following sections.

NOTE: In the following tables, * indicates an optional parameter and bold legal values are default.

5.1 Client Side Connection Parameters

Section Title		
Connections		
Column Title	Function	Legal Values
Adapter	Specify which adapter this protocol uses.	N1-N2, WLAN ⁴
Protocol	Specify protocol used.	Modbus/TCP
Poll Delay*	Time interval between polls.	0-32000 s, 0.05 s
Max_Concurrent_Messages* ⁵	Specify the maximum messages the driver can send, before waiting for responses.	0 – 65534 (0 or 1 disables concurrent messaging meaning only 1 active message at a time)

Example:

```
// Client Side Connections

Connections
Adapter      , Protocol      , Poll_Delay
N1           , Modbus/TCP    , 0.05s
```

⁴ Not all ports shown are necessarily supported by the hardware. Consult the appropriate instruction manual for details of the ports available on specific hardware.

⁵ Using Max_Concurrent_Messages value > 1 could improve communication performance, but it also depends on the remote Server's implementation. The server might not support multiple messaging, so match this number with the Server's capability.

5.2 Client Side Node Parameters

Section Title		
Nodes		
Column Title	Function	Legal Values
Node_Name	Provide name for node.	Up to 32 alphanumeric characters
Node_ID	Station Address of Remote Server Node.	0 – 255
Protocol	Specify protocol used.	Modbus/TCP
Adapter	Specify which adapter this protocol uses.	N1-N2, WLAN ⁶
IP_address	IP address of client PLC.	Valid IP address (for example - 192.168.1.13)
Address_Type ⁷	Specify Register Mapping Model.	ADU, PDU, Modicon_5digit
Modbus_TCP_IP_Port*	Select remote Internet Protocol Port.	1-65534, 502
Write_Fnc*	Set to Multiple if Remote Server Node only supports Write Multiple function code 15 & 16.	Multiple, -
Write_Length*	Set to MD_Length if write-thru operation should write all registers as specified by MD_Length. By default, write-thru writes a single register. If Write_Length also specified on Map Descriptor, Map Descriptor's parameter will be used.	MD_Length, -, 1

Example

```
// Client Side Nodes for new devices where 65536 registers are available in each memory area

Nodes
Node_Name      , Node_ID      , Protocol      , Adapter      , Address_Type  , IP_Address
Modbus device 1 , 1          , Modbus/TCP   , N1           , ADU           , 192.168.1.172
```

```
// Client Side Nodes for devices where only 9999 registers are available in each memory area

Nodes
Node_Name      , Node_ID      , Protocol      , Adapter      , IP_Address
Modbus device 3 , 3          , Modbus/TCP   , N1           , 192.168.1.172
```

⁶ Not all ports shown are necessarily supported by the hardware. Consult the appropriate Instruction manual for details of the ports available on specific hardware.

⁷ Optional for Modicon 5 digit devices.

5.3 Client Side Map Descriptor Parameters

5.3.1 FieldServer Specific Map Descriptor Parameters

Column Title	Function	Legal Values
Map_Descriptor_Name	Name of this Map Descriptor.	Up to 32 alphanumeric characters
Data_Array_Name	Name of Data Array where data is to be stored in the FieldServer.	One of the Data Array names from Section 4
Data_Array_Offset	Starting location in Data Array.	0 to (Data_Array_Length -1) as specified in Section 4
Function	Function of Client Map Descriptor.	RDBC, WRBC, WRBX, Passive

5.3.2 Driver Specific Map Descriptor Parameters

Column Title	Function	Legal Values
Node_Name	Name of Node to fetch data from.	One of the Node names specified in Section 5.2
Data_Type ⁸	Specify memory area. Refer to Section 7.1.2 on how to transfer 32 Bit values using Modbus registers.	Address_Type = ADU Coil, Discrete_Input, Input_Register, Holding_Register, Single_Coil, Single_Register, Slave_ID
		Address_Type = PDU FC01, FC02, FC03, FC04, FC05, FC06, FC15, FC16
Address	Starting address of read block.	Address_Type = Modicon_5digit - (Dash), Single_Register, Single_Coil
		All Address_Type Float_Reg, 32Bit_Reg, Input_Float, Input_Reg_32Bit, Float_Reg_Swap, 32Bit_Reg_Swap, Input_Float_Swap, Input_Reg_32Bit_Swap (Section 7.4.1); Input_Reg_64Bit, 64Bit_Reg, Input_Double, Double_Reg (Section 7.4.3); Reg_Bytes, Input_Reg_Bytes, Reg_Bits, Input_Reg_Bits (Section 7.3); Device_ID (Section 7.5.1)
Length*	Length of Map Descriptor.	Address_Type = ADU 1-65536
		Address_Type = PDU 0-65535
		Address_Type = Modicon_5digit 40001, 30001, etc.
		Address_Type Float_Reg, 32-Bit_Reg, Input_Float, Input_Reg_32Bit
		1-125 (for Analog polls), 1-800 (for Binary polls)

⁸ Optional only for Modicon_5digit addressing, and only if Single writes do not need to be forced.

Scattered_Addresses*	Specify additional addresses to read on this map descriptor.	List of addresses separated by a space, all within quotation marks (Section 7.7)
Write_Length*	Set to MD_Length if write-thru operation should write all registers as specified by length parameter. By default, write-thru writes a single register.	MD_Length, -, 1
Data_Array_Low_Scale*	Scaling zero in Data Array.	Any signed 32 bit integer in the range: -2,147,483,648 to 2,147,483,647, 0
Data_Array_High_Scale*	Scaling max in Data Array.	Any signed 32 bit integer in the range: -2,147,483,648 to 2,147,483,647, 100
Node_Low_Scale*	Scaling zero in Connected Node.	Any signed 32 bit integer in the range: -2,147,483,648 to 2,147,483,647, 0
Node_High_Scale*	Scaling max in Connected Node.	Any signed 32 bit integer in the range: -2,147,483,648 to 2,147,483,647, 100
Object_ID*	Only used with Data_Type Device_ID.	0- 6 (Section 7.5.1)

5.3.3 Timing Parameters

Column Title	Function	Legal Values
Scan_Interval*	Rate at which data is polled.	0-32000, 20

5.4 Map Descriptor Examples

All three examples below are addressing the same Modbus registers:

```
// Client Side Map Descriptors for Nodes where Address_Type is ADU
Map_Descriptors
Map_Descriptor_Name, Data_Array_Name, Data_Array_Offset, Function, Node_Name, Data_Type, Address, Length, Scan_Interval
CMD_AI_01, DA_AI_01, 0, Rdbc, MODBUS DEVICE1, Input_Register, 1, 20, 1.000s
CMD_AO_01, DA_AO_01, 0, Rdbc, MODBUS DEVICE1, Holding_Register, 1, 20, 1.000s
CMD_DI_01, DA_DI_01, 0, Rdbc, MODBUS DEVICE1, Discrete_Input, 1, 20, 1.000s
CMD_DO_01, DA_DO_01, 0, Rdbc, MODBUS DEVICE1, Coil, 1, 20, 1.000s
```

```
// Client Side Map Descriptors for Nodes where Address_Type is PDU
Map_Descriptors
Map_Descriptor_Name, Data_Array_Name, Data_Array_Offset, Function, Node_Name, Data_Type, Address, Length, Scan_Interval
CMD_AI_02, DA_AI_02, 0, Rdbc, MODBUS DEVICE2, FC04, 0, 20, 1.000s
CMD_AO_02, DA_AO_02, 0, Rdbc, MODBUS DEVICE2, FC03, 0, 20, 1.000s
CMD_DI_02, DA_DI_02, 0, Rdbc, MODBUS DEVICE2, FC02, 0, 20, 1.000s
CMD_DO_02, DA_DO_02, 0, Rdbc, MODBUS DEVICE2, FC01, 0, 20, 1.000s
```

```
// Client Side Map Descriptors for Nodes where Address_Type is Modicon_5digit
Map_Descriptors
Map_Descriptor_Name, Data_Array_Name, Data_Array_Offset, Function, Node_Name
CMD_AI_03, DA_AI_03, 0, Rdbc, MODBUS DEVICE3
CMD_AO_03, DA_AO_03, 0, Rdbc, MODBUS DEVICE3
CMD_DI_03, DA_DI_03, 0, Rdbc, MODBUS DEVICE3
CMD_DO_03, DA_DO_03, 0, Rdbc, MODBUS DEVICE3
```

, Address	, Length	, Scan_Interval	Map_Descriptor_Name
, 30001	, 20	, 1.000s	CMD_AI_03
, 40001	, 20	, 1.000s	CMD_AO_03
, 10001	, 20	, 1.000s	CMD_DI_03
, 00001	, 20	, 1.000s	CMD_DO_03

6 Configuring the FieldServer as a Server

For detailed information on FieldServer configuration, refer to the FieldServer Configuration Manual. The information that follows describes how to expand upon the factory defaults provided in the configuration files included with the FieldServer (see “.csv” sample files provided with the FieldServer).

This section documents and describes the parameters necessary for configuring the FieldServer to communicate with a Modbus TCP/IP Client.

The configuration file tells the FieldServer about its interfaces, and the routing of data required. In order to enable the FieldServer for Modbus TCP/IP communications the following three actions must be taken. The driver independent FieldServer buffers need to be declared in the “Data Arrays” section. The FieldServer virtual Node(s) need to be declared in the “Server Side Nodes” section. And the data to be provided to the client(s) needs to be mapped in the “Server Side Map Descriptors” section. Details on how to perform these steps can be found in the following sections.

NOTE: In the following tables, * indicates an optional parameter and bold legal values are default.

6.1 Server Side Connection Parameters

Section Title		
Connections		
Column Title	Function	Legal Values
Adapter	Specify which adapter this protocol uses.	N1-N2, WLAN ⁹
IP_Port	Specify internet protocol Port.	1-65534
Protocol	Specify protocol used.	Modbus/TCP
Framing_Timeout*	Sets the time to wait for a message frame to complete on the network. This is useful on busy Modbus networks where unknown messages for other devices may cause longer timeouts.	0 (disabled), 1 - 100 milliseconds, 100
Max_Sessions*	The maximum sessions that will be accepted by the server side. Any connection requests after the number of open sessions reaches this number will result in the session that was last active being closed.	1-65534, 20
Inactivity_Timeout*	Specify the connection inactivity timeout in seconds. The FieldServer will close the connection opened by the client if there is no activity for this time period.	0 – 4294967, 60
Accept_Broadcast*	Specify server to accept broadcast messages.	Yes, No
Multiple_Server_Messages*	Enable or disable the ability to parse multiple messages in a stream. Selecting “No” will only parse the first message and discard the rest.	Yes , No

Example

```
// Server Side Connections
Connections
Adapter      , Protocol
N1           , Modbus/TCP
```

⁹ Not all ports shown are necessarily supported by the hardware. Consult the appropriate Instruction manual for details of the ports available on specific hardware.

6.2 Server Side Node Parameters

Section Title		
Nodes		
Column Title	Function	Legal Values
Node_Name	Provide name for node.	Up to 32 alphanumeric characters
Node_ID	Node ID of physical Server Node.	0 – 255 (optional)
Protocol	Specify protocol used.	Modbus/TCP
Address_Type* ¹⁰	Specify Register Mapping Model.	ADU, PDU, Modicon_5digit
Node_Offline_Response*	Set the FieldServer response to the Modbus TCP/IP Client when the Server Node supplying the data has gone offline.	Gateway_Device_Failed, Exception_B, No_Response, Old_Data, Zero_Data, FFFF_Data; see Section 7.2
Node_Description*	Specify Node description text.	Any string up to 99 characters long, -
Partial_Data_Response*	Set the FieldServer's response to the Modbus TCP/IP Client request when addresses are not defined in the Map Descriptor section.	Do_not_Respond, Fill_Gaps_With_Zero, Fill_Gaps_With_FFFF

NOTE: For this protocol, the IP address for the FieldServer is configured using the "I" menu option on the Remote User Interface.

Example

```
// Server Side Nodes for new devices where 65536 registers are available in each memory area

Nodes
Node_Name      , Node_ID      , Protocol      , Address_Type
MB_Srv_11      , 11      , Modbus/TCP    , ADU
MB_Srv_12      , 12      , Modbus/TCP    , PDU
```

```
// Server Side Nodes for devices where only 9999 registers are available in each memory area

Nodes
Node_Name      , Node_ID      , Protocol      , Address_Type
MB_Srv_13      , 13      , Modbus/TCP    , Modicon_5digit
MB_Srv_14      , 14      , Modbus/TCP    , -
```

¹⁰ Optional for Modicon 5 digit devices.

6.3 Server Side Map Descriptor Parameters

6.3.1 FieldServer Specific Map Descriptor Parameters

Column Title	Function	Legal Values
Map_Descriptor_Name	Name of this Map Descriptor.	Up to 37 alphanumeric characters
Data_Array_Name	Name of Data Array where data is to be stored in the FieldServer.	One of the Data Array names from Section 4
Data_Array_Offset	Starting location in Data Array.	0 to (Data_Array_Length-1) as specified in Section 4
Function	Function of Server Map Descriptor.	Passive, server

6.3.2 Driver Specific Map Descriptor Parameters

Column Title	Function	Legal Values
Node_Name	The name of the Node being represented.	One of the Node names specified in Section 6.2
Data_Type ¹¹	Specify memory area.	Address_Type = ADU
		Coil, Discrete_Input, Input_Register, Holding_Register, Single_Coil, Single_Register, Slave_ID (Section 6.4.1)
		Address_Type = PDU
		FC01, FC02, FC03, FC04, FC05, FC06, FC15, FC16
		Address_Type = Modicon_5digit
		- (Dash), Single_Register, Single_Coil
		All Address_Type
Address	Starting address of read block.	Device_ID (Section 7.5.1)
		Address_Type = ADU
		1-65536
		Address_Type = PDU
		0-65535
Length*	Length of Map Descriptor.	Address_Type = Modicon_5digit
		40001, 30001, etc.
		Address_Type = ADU
		1-65536
		Address_Type = PDU
Data_Array_Low_Scale*	Scaling zero in Data Array.	1-65536
		Address_Type = Modicon_5digit
Data_Array_High_Scale*	Scaling max in Data Array.	1-9999
		Address_Type = Modicon_5digit
Node_Low_Scale*	Scaling zero in connected Node.	Any signed 32 bit integer in the range: -2147483648 to 2147483647, 0
Node_High_Scale*	Scaling max in connected Node.	Any signed 32 bit integer in the range: -2147483648 to 2147483647, 100

¹¹ Optional only for Modicon_5digit addressing, and only if Single writes do not need to be forced.

6.4 Map Descriptor Examples

All three examples below are addressing the same Modbus registers:

```
// Client Side Map Descriptors for Nodes where Address_Type is ADU
```

Map_Descriptors	Map_Descriptor_Name	Data_Array_Name	Data_Array_Offset	Function	Node_Name	Data_Type	Address
	SMD_AI_01	DA_AI_01	0	Passive	MB_Srv_11	Input_Register	1
	SMD_AO_01	DA_AO_01	0	Passive	MB_srv_11	Holding_Register	1

Data_Array_Low_Scale	Data_Array_High_Scale	Node_Low_Scale	Node_High_Scale
0	100	0	10000
0	100	0	10000

```
// Client Side Map Descriptors for Nodes where Address_Type is PDU
```

Map_Descriptors	Map_Descriptor_Name	Data_Array_Name	Data_Array_Offset	Function	Node_Name	Data_Type	Address
	SMD_AI_02	DA_AI_02	0	Passive	MB_Srv_12	FC04	0
	SMD_AO_02	DA_AO_02	0	Passive	MB_srv_12	FC03	0

Data_Array_Low_Scale	Data_Array_High_Scale	Node_Low_Scale	Node_High_Scale
0	100	0	10000
0	100	0	10000

```
// Client Side Map Descriptors for Nodes where Address_Type is Modicon_5digit
```

Map_Descriptors	Map_Descriptor_Name	Data_Array_Name	Data_Array_Offset	Function	Node_Name	Address	Length
	SMD_AI_01	DA_AI_01	0	Passive	MBP_Srv_13	30001	200
	SMD_AO_01	DA_AO_01	0	Passive	MBP_Srv_13	40001	200

Data_Array_Low_Scale	Data_Array_High_Scale	Node_Low_Scale	Node_High_Scale
0	100	0	10000
0	100	0	10000

6.4.1 Slave_ID

The Node_Description will automatically be used to respond to the Report Slave_ID request (Function Code 17 or FC17). If the Node_Description is not defined the title in the common information section will be used as the description in the Slave_ID response.

Slave ID Lookup in Table

The Slave_ID will be read from device PLC_21. The response will be searched for occurrences of the strings in the table in column table string. If a match is found the **user** value will be written.

The Table_String must occur in the Slave_ID in any position.

Config_Table	Config_Table_Name	Table_String	Table_Index_Value	Table_User_Value
	slave_id_profile	FS01	1	1
	slave_id_profile	FS02	2	2
	slave_id_profile	FS03	3	3

Map_Descriptors	Map_Descriptor_Name	Data_Array_Name	Data_Array_Offset	Function	Node_Name	Scan_Interval
	CMD_DO_01	DA_DO_01	0	RDBC	PLC_21	0.000s

Data_Type	Length	Config_Table_Name
Slave_Id	1	slave_id_profile

7 Useful Features

7.1 Managing Floating Points with Modbus

Modbus as a standard does not support floating point formats. Many vendors have written higher level communications software to use two 16 bit registers to represent floating point or 32 bit integers. This requires conversion software on both ends of the communication channel. The FieldServer supports this function and also provides other options to resolve this issue.

7.1.1 Transferring Non-integer Values with One Register

It is possible to represent values higher than 32767 using one register in one of two ways:

- Declare data arrays as type Uint16 (Unsigned integer); this allows a range from 0 to 65535.
- Use the scaling function on the FieldServer, which allows any range with 16 bit resolution.

The following example shows how scaling can be achieved on the Server side of the configuration.

NOTE: Scaling can also be done on the Client side to scale down a value that was scaled up by a Modbus vendor. Further information regarding scaling, refer to the [FieldServer Configuration Manual](#), found on the Sierra Monitor website.

Example

Map_Descriptors						
Map_Descriptor_Name	Data_Array_Name	Data_Array_Offset	Function	Node_Name	Address	Length
SMD_AI1	DA_AI_01	,0	,Passive	MBP_Srv_11	,30001	,200
SMD_AO1	DA_AO_01	,0	,Passive	MBP_Srv_11	,40001	,200

Data_Array_Low_Scale	Data_Array_High_Scale	Node_Low_Scale	Node_High_Scale
,0	,100	,0	,10000
,0	,100	,0	,10000

This example multiplies the values in the data array by 100 (10000 on Node_High_Scale is 100X larger than 100 on Data_Array_High_Scale). This is most commonly used when the user wants to introduce values after the decimal point. For example, a value of 75.6 will be sent as 7560, which can then be rescaled by the Modbus master.

7.1.2 Transferring Float/32 bit Values with Two Registers

If a Modbus Server sends two consecutive registers to the FieldServer representing either a floating point value or a 32 bit integer value, the FieldServer can combine and decode these registers back into their original format. To do this, declare Data Array of type Float or UINT32 and set the Map Descriptor Data_Type as 'Float_Reg', '32Bit_Reg', etc.

Example

Data_Arrays			
Data_Array_Name	Data_Format	Data_Array_Length	
DA1	Float	20	
DA2	UInt32	20	
DA3	Float	20	
DA4	UInt32	20	

// Client Side Map Descriptors where Nodes where Address_Type is PDU				
Map_Descriptors				
Map_Descriptor_Name	Data_Array_Name	Data_Array_Offset	Function	Node_Name
CMD_AO_01	DA1	0	Rdbc	Modbus Device2
CMD_AO_02	DA2	0	Rdbc	Modbus Device2
CMD_AI_01	DA3	0	Rdbc	Modbus Device2
CMD_AI_02	DA4	0	Rdbc	Modbus Device2

Data_Type	Address	Length	Scan_Interval
Float_Reg	0	20	1.000s
32Bit_Reg	0	20	1.000s
Input_Float	0	20	1.000s
Input_Reg_32Bit	0	20	1.000s

Each Map Descriptor will read 20 pairs of registers and store them as a 32-bit floating number or a 32-bit Integer.

If the server device sends swapped registers (low value register first) then use the corresponding _swap data_types.

NOTE: The value in the address parameter can be ADU, PDU or Modicon 5-digit types; see Section 5.3.2.

7.2 Node_Offline_Response

In systems where data is being collected from multiple Server Nodes and made available on a FieldServer configured as a Modbus TCP/IP Server, when a Server Node goes offline the default behavior of the FieldServer would be to stop responding to polls for this data. This might not be what the user wants. Various options exist making it possible to signal that the data quality has gone bad without creating error conditions in systems sensitive to the default option.

The following options can be configured under the Node parameter, Node_Offline_Response, to set the response of the FieldServer to the Modbus TCP/IP Client when the Server Node supplying the data is offline:

- **No_Response** - This is the default option. The FieldServer simply does not respond when the corresponding Server Node is offline.
- **Old_Data** - The FieldServer responds with the last known data value. This maintains the communication link in an active state, but may hide the fact that the Server Node is offline.
- **Zero_Data** - The FieldServer responds with the data values set to zero. If the user expects non-zero values, this option will signal the offline condition without disrupting communications.
- **FFFF_Data** - The FieldServer responds with data values set to FFFF (hex). If the user expects other values, this option will signal the offline condition without disrupting communications.

When configured as a Server this parameter can force a desired exception response as follows :

- Node_Offline_Message or Exception_4 - FieldServer's response will be Exception 4.
- Gateway_Path_Unavailable or Exception_A - FieldServer's response will be Exception A.
- Gateway_Device_Failed or Exception_B - FieldServer's response will be Exception B.

Example

Node Name	Node_ID	Protocol	Node_Offline_Response	Port
DEV11	, 11	, Modbus/TCP	, No_Response	, -
DEV12	, 12	, Modbus/TCP	, Old_Data	, -
DEV15	, 15	, Modbus/TCP	, Zero_Data	, -
DEV16	, 16	, Modbus/TCP	, FFFF_Data	, -
DEV17	, 17	, Modbus/TCP	, Exception_4	, -
DEV18	, 18	, Modbus/TCP	, Gateway_Path_Unavailable	, -

7.3 Splitting Registers into Bytes or Bits

Sometimes it is required to split a register into Bytes or bits. The following Map Descriptors read registers and store the bytes/bits in consecutive data array locations. The FieldServer will store the least significant byte/bit at the 1st offset and will continue sequentially. To implement this feature, declare a Data Array with Data_Format Byte or bit and use that Data_Array_Name when setting up the Map_Descriptor parameters. In the Map_Descriptors, set Data_Type as 'Reg_Bytes' or 'Reg_Bits' according to the Data_Format of the Data_Array.

Example

Data_Arrays		
Data_Array_Name	Data_Format	Data_Array_Length
DA1	, Byte	, 40
DA2	, Byte	, 40
DA3	, Bit	, 320
DA4	, Bit	, 320

//Client Side Map Descriptors for Nodes where Address_Type is PDU								
Map_Descriptors								
Map_Descriptor_Name	Data_Array_Name	Data_Array_Offset	Function	Node_Name	Data_Type	Address	Length	Scan_Interval
CMD_AO_01	, DA1	, 0	, RDBC	, ModbusDevice2	, Reg_Bytes	, 0	, 40	, 1.000s
CMD_AO_02	, DA2	, 0	, RDBC	, ModbusDevice2	, Input_Reg_Bytes	, 0	, 40	, 1.000s
CMD_AI_01	, DA3	, 0	, RDBC	, ModbusDevice2	, Reg_Bytes	, 0	, 320	, 1.000s
CMD_AI_02	, DA4	, 0	, RDBC	, ModbusDevice2	, Input_Reg_Bytes	, 0	, 320	, 1.000s

Each Map Descriptor will read 20 registers and store them as 40 bytes or 320 bits.

7.4 Reading Data Types

7.4.1 32-Bit Integer and Float Data Types

When a Modbus slave device needs to pass a 32-Bit Integer or a 32-Bit Float, it splits the float into two 16-bit Integers and maps it to consecutive registers. The following data types read the 2 consecutive registers and auto combines them into a 32-Bit Integer or Float before storing it in a Data Array.

- Float_Reg (32-Bit IEEE 754 Floating Point in Holding Register FC03)
- 32Bit_Reg (32-Bit Integer in Holding Register FC03)
- Input_Float (32-Bit IEEE 754 Floating Point in Input Register FC04)
- Input_Reg_32Bit (32-Bit Integer in Input Register FC04)
- Float_Reg_Swap (32-Bit IEEE 754 Floating Point with swapped format in Holding Register FC03)
- 32Bit_Reg_Swap (32-Bit Integer with swapped format in Holding Register FC03)
- Input_Float_Swap (32-Bit IEEE 754 Floating Point with swapped format in Input Register FC04)
- Input_Reg_32Bit_Swap (32-Bit Integer with swapped format in Input Register FC04)

Example

Data_Arrays		
Data_Array_Name	Data_Format	Data_Array_Length
DA_U32_01	, Uint32	, 20
DA_FLT_01	, Float	, 20

Accessing Priority Array Information

The Priority Array table and its "In_Use" (or Not Relinquished) state are stored internally to every Map Descriptor and cannot be accessed directly. The information can be accessed indirectly by specifying the following Data Arrays which will maintain an exact copy of the Priority Array Table for the Map Descriptor.

Section Title	Function	Legal Values
Map Descriptors		
Column Title	Function	Legal Values
DA_Pri_Array	Name of Data Array where the Priority Array Table will be stored. Location 0 is the Relinquish Default value and locations 1 to 16 the different entries of the Priority Array Table.	Up to 16 alphanumeric characters
DA_Pri_Array_Offset*	Starting location in Data Array.	1-65535, 0
DA_Pri_In_Use	Name of Data Array that indicates if a specific Priority Value is in use. Location 0 indicates whether the Relinquish Default has been set and locations 1 to 16 indicate whether the index is in use (1), or Relinquished (0).	Up to 16 alphanumeric characters
DA_Pri_In_Use_Offset*	Starting location in Data Array.	1-65535, 0

```
// Analog Output Map_Descriptor for testing Priority Arrays
Map_Descriptors
Map_Descriptor_Name ,Data_Type ,Object_ID ,Function ,Data_Array_Name ,Data_Array_Index ,Node_Name ,Length
CMD_AOP_1 ,AO ,1 ,Passive ,DA_OUT ,0 ,N1_11 ,1

,Relinquish_default ,DA_Pri_Array ,DA_Pri_Array_Offset ,DA_Pri_In_Use ,DA_Pri_In_Use_Offset
,40.56 ,DA_Pri_Array_1 ,0 ,DA_Pri_in_use_1 ,0
```

7.4.2 Relinquishing Control of a Point as a Client

It is possible to relinquish control of a point by writing a null to the correct priority level. The following example illustrates how this is done.

```
Map_Descriptors
Map_Descriptor_Name ,Data_Type ,Function ,Scan_Interval ,Data_Array_Name ,Data_Array_Index
CMD_AO ,AO ,Rdbc ,1.0s ,DA_AO ,2
CMD_AO_Rel ,AO ,Wrbc ,1.0s ,DA_AO ,3

,Node_Name ,Address ,Length ,Write_Priority ,Service
,N1_1 ,1 ,1 ,7 ,
,N1_1 ,1 ,1 ,7 ,Relinquish
```

In the above example:

- Map_Descriptor_Name CMD_AO is a Read Map Descriptor that will write at priority 7 if a write-through occurs.
- Map_Descriptor_Name CMD_AO_Rel is a Write-on-Change Map Descriptor that will write a NULL at priority 7 (i.e. release Priority Array entry 7) when a write occurs.
- Address parameter length must be 1 as shown above.

```
//Client Side Map Descriptors
Map_Descriptors
Map_Descriptor_Name ,Data_Array_Name ,Data_Array_Offset ,Function ,Node_Name ,Data_Type ,Address ,Length ,Scan_Interval
CMD_01 ,DA_FLT_01 ,0 ,RDBC ,Dev_01 ,Float_Reg ,40001 ,1 ,0.000s
CMD_02 ,DA_U32_01 ,0 ,RDBC ,Dev_01 ,32Bit_Reg ,40003 ,1 ,0.000s
CMD_03 ,DA_FLT_01 ,1 ,RDBC ,Dev_01 ,Input_Float ,30001 ,1 ,0.000s
CMD_04 ,DA_U32_01 ,1 ,RDBC ,Dev_01 ,Input_Reg_32Bit ,30003 ,1 ,0.000s
CMD_05 ,DA_FLT_01 ,2 ,RDBC ,Dev_01 ,Float_Reg_Swap ,40005 ,1 ,0.000s
CMD_06 ,DA_U32_01 ,2 ,RDBC ,Dev_01 ,32Bit_Reg_Swap ,40007 ,1 ,0.000s
CMD_07 ,DA_FLT_01 ,3 ,RDBC ,Dev_01 ,Input_Float_Swap ,30005 ,1 ,0.000s
CMD_08 ,DA_U32_01 ,3 ,RDBC ,Dev_01 ,Input_Reg_32Bit_Swap ,30007 ,1 ,0.000s
```

7.4.3 64-Bit Integer and Float Data Types

When a Modbus slave device needs to pass a 64-Bit Integer or a 64-Bit Float, it splits the float into four 16-bit Integers and maps it to consecutive registers. The following data types read the 4 consecutive registers and auto combines them into a 64-Bit Integer or Float, before the scaling is applied (to keep the decimal precision) and stores the scaled value in a Data Array. When serving the value to the output protocol, the reverse scaling needs to be applied.

- 64Bit_Reg (64-Bit Integer in Holding Register FC03)
- Double_Reg (64-Bit IEEE 754 Floating Point in Holding Register FC03)
- Input_Reg_64bit (64-Bit Integer in Input Register FC04)
- Input_Double (64-Bit IEEE 754 Floating Point in Input Register FC04)

Example

Data_Arrays		
Data_Array_Name	Data_Format	Data_Array_Length
DA_U32_01	Uint32	20
DA_FLT_01	Float	20

```
//Client Side Map Descriptors
, Map_Descriptors
, Map_Descriptor_Name , Data_Array_Name , Data_Array_Offset , Function , Node_Name , Data_Type , Address , Length , Scan_Interval
, CMD_01 , DA_U32_01 , 0 , RDBC , Dev_01 , 64Bit_Reg , 40001 , 1 , 0.000s
, CMD_02 , DA_FLT_01 , 0 , RDBC , Dev_01 , Double_Reg , 40003 , 1 , 0.000s
, CMD_03 , DA_U32_01 , 1 , RDBC , Dev_01 , Input_Reg_64bit , 30001 , 1 , 0.000s
, CMD_04 , DA_FLT_01 , 1 , RDBC , Dev_01 , Input_Double , 30003 , 1 , 0.000s
```

Data_Array_Low_Scale	Data_Array_High_Scale	Node_Low_Scale	Node_High_Scale
0	1	0	1000000000
0	1	0	1000000000
0	1	0	1000000000
0	1	0	1000000000

Nodes		
Node_Name	Node_ID	Protocol
Virtual_Dev_11	11	Bacnet_IP

```
//Client Side Map Descriptors
, Map_Descriptors
, Map_Descriptor_Name , Data_Array_Name , Data_Array_Offset , Function , Node_Name , Object Type , Object Instance
, SMD_11_AI_01 , DA_U32_01 , 0 , Passive , Virtual_Dev_11 , AI , 1
, SMD_11_AI_02 , DA_FLT_01 , 0 , Passive , Virtual_Dev_11 , AI , 2
, SMD_11_AI_03 , DA_U32_01 , 1 , Passive , Virtual_Dev_11 , AI , 3
, SMD_11_AI_04 , DA_FLT_01 , 1 , Passive , Virtual_Dev_11 , AI , 4
```

Data_Array_Low_Scale	Data_Array_High_Scale	Node_Low_Scale	Node_High_Scale
0	1	0	1000000000
0	1	0	1000000000
0	1	0	1000000000
0	1	0	1000000000

7.5 Reading Device Identification

7.5.1 Client Side Map Descriptor

There could be various objects describing device identification. Each object has its own ID (0-255). Only the first 7 ID's (0-6) objects are defined and are ASCII Strings.

Object ID	Object Name
0	VendorName
1	ProductCode
2	MajorMinorRevision
3	VendorUrl
4	ProductName
5	ModelName
6	UserApplicationName

The Client Side Map Descriptors read the specified object from a remote device. They will store the object data character-by-character in the specified data array, up to the limit specified by the Map Descriptor length.

Any object could have up to 248 characters.

```
//Client Side Map Descriptors
Map_Descriptors
Map_Descriptor_Name ,Data_Array_Name ,Data_Array_Offset ,Function ,Node_Name ,Data_Type ,Address ,Length
CMD_Vendor_name ,DA_Vendor ,0 ,Server ,PLC_01 ,Device_Id ,0 ,248
CMD_Product_code ,DA_Prodcode ,0 ,Server ,PLC_01 ,Device_Id ,1 ,248
```

7.5.2 Server Side Map Descriptor

Server Side Map Descriptors can define any object as shown below. The Driver will serve strings from the data array as an object value. The string from the data array is considered complete if the character is 0 (null) or if all characters are fetched as per the Map Descriptor length.

If the first character is 0 (null) then the single character '-' will be used as the object value.

```
//Server Side Map Descriptors
Map_Descriptors
Map_Descriptor_Name ,Data_Array_Name ,Data_Array_Offset ,Function ,Node_Name ,Data_Type ,Address ,Length
CMD_Vendor_name ,DA_Vendor ,0 ,Server ,PLC_01 ,Device_Id ,0 ,248
CMD_Product_code ,DA_Prodcode ,0 ,Server ,PLC_01 ,Device_Id ,1 ,248
```

7.6 Broadcasting Write Messages

Standard Modbus TCP/IP node addresses range from 1 to 254, with 0 being reserved for broadcast messages. Setting the Node ID to 0 allows write messages to be broadcast to all configured slave devices.

To perform a valid broadcast, the node ID will need to be set to 0 and the map-descriptor function will need to be set to a write.

Example

```
// Client Side Nodes
Nodes
Node_Name ,Node_ID ,Protocol ,Port ,Address_Type
BROADCAST_NODE ,0 ,Modbus/TCP ,R2 ,PDU
```

```
//Client Side Map Descriptors
Map_Descriptors
Map_Descriptor_Name ,Data_Array_Name ,Data_Array_Offset ,Function ,Node_Name ,Data_Type ,Address ,Length ,Scan_Interval
CMD_AO_01 ,DA1 ,0 ,RDBC ,ModbusDevice2 ,Reg_Bytes ,0 ,40 ,1.000s
CMD_AO_02 ,DA2 ,0 ,RDBC ,ModbusDevice2 ,Input_Reg_Bytes ,0 ,40 ,1.000s
```

7.7 Reading Scattered Addresses

This function enables the user to read non-contiguous registers. It also avoids multiple polls using function 3 or 4 to read non-contiguous registers.

The following is an example to show the request and response to read input registers (sub function 0x04) 101 (0x65), 114 (0x72) and 149 (0x95) from Slave_ID 33 (0x21).

Poll request example:

Parameter	Value
Modbus slave address	0x21
Function code	0x64
Data length in bytes	0x06
Sub-function code	0x04 (0x03 to read holding registers)
Transmission number	0xXX
Address of 1st word to read (MSB)	0x00
Address of 1st word to read (LSB)	0x65
Address of 2nd word to read (MSB)	0x00
Address of 2nd word to read (LSB)	0x72
Address of 3rd word to read (MSB)	0x00
Address of 3rd word to read (LSB)	0x95
CRC MSB	0xXX
CRC LSB	0xXX

Suppose the value of register 101 is 3000, register 114 is 6000 and register 149 is 9000. The following would be the response from the slave:

Parameter	Value
Modbus slave address	0x21
Function code	0x64
Data length in bytes	0x06
Sub-function code	0x04 (same as in request)
Transmission number	0xXX (same as in request)
1st register value (MSB)	0x0B
1st register value (LSB)	0xB8
2nd register value (MSB)	0x17
2nd register value (LSB)	0x70
3rd register value (MSB)	0x23
3rd register value (LSB)	0x28
CRC MSB	0xXX
CRC LSB	0xXX

Following is the corresponding Client Map Descriptor example, it will read 3 scattered addresses and will store in data array DA_AI_01 at offset 0, 1 and 2.

```
//Client Side Map Descriptors
Map_Descriptors
Map_Descriptor_Name , Data_Array_Name , Data_Array_Offset , Function , Node_Name , Address , Length , Scattered_Addresses
CMD_Scattered_Read , DA_AI_01 , 0 , RDBC , PLC_33 , 30102 , 3 , "30115 30150"
```

On the server side, no configuration changes are required to support the scattered read function. Ensure that all registers are configured. Registers can be configured in a single Server Map Descriptor range or scattered over multiple Server Map Descriptors.

8 Troubleshooting

8.1 Server Configuration of System Station Address

When using the FieldServer as a Modbus Server, the FieldServer System Station address must be configured to be different from any of the configured Modbus Server Node_ID's. Configuring these to be the same invokes proprietary system information to be transmitted and should therefore be avoided.

8.2 Modbus TCP/IP Connection Error Descriptions

No Start – An Ethernet connection cannot be established to the specified IP Address.

TCP Connection Lost – An Ethernet connection was established to the specified IP Address but the connection was terminated or lost.

Timeout – An Ethernet connection was established to the specified IP Address and a Modbus request was sent but the device did not respond before the timeout interval expired.

8.3 Understanding Max Concurrent Messages

The FieldServer Max_Concurrent_Messages parameter enables polling multiple “threads” for the Modbus TCP/IP Driver; increasing network communications speed if the FieldServer is a Modbus Master. This feature can significantly improve communication speeds but may also create minor communication errors with other vendors' devices. Most often, this does not prevent communication but creates a small percentage of communication errors. These errors must be accepted to utilize this feature.

Consider an application where one communication thread is used to poll four devices. This sequence includes the following steps:

1. Poll device 1 and wait for a response to be received.
2. Poll device 2 and wait for a response to be received.
3. Poll device 3 and wait for a response to be received.
4. Poll device 4 and wait for a response to be received.
5. Poll device 5 and wait for a response, then go back to step 1.

Now consider five threads for the communication. Then the sequence follows:

1. Poll devices 1,2,3,4 and 5 at the same time and wait for the individual responses to come back.
2. As each thread is freed up, poll the next device in line and continue.

This example shows how using multiple threads is substantially faster but additionally, if one of the devices is faulty then the network is influenced far less when five threads are used.

- In the single thread scenario, communication must wait for the faulty device and when it doesn't respond (after 2 seconds) it moves on. This is a significant delay.
- In the five thread scenario, only one thread waits while the other threads communicate freely.

A typical Modbus slave device should be able to handle multiple thread situations. However, it is common practice to request multiple mappings (register sets) from each device, and each mapping represents a poll. With one thread, a request for multiple mappings from the same device at the same time is not possible, but with multiple threads this situation can occur. Because this is not a common scenario, individual vendor devices respond to this situation differently and may not respond at all when given a multiple request. If this happens, the FieldServer logs errors and no communication occurs, but when the FieldServer polls the same device a bit later and there is no second poll request active the response will succeed. Therefore, device communication is still intact and these errors represent no significant problem.

In Summary, although setting `Max_Concurrent_Messages > 1` causes errors in communication, these errors are often not serious and the benefits of Multi-threading are great enough to tolerate the errors.

It is recommended to start testing around a value of 5 to determine the best setting for this parameter. Increasing the parameter increases communication speed but may also increase errors significantly. Setting the parameter to 1, switches multi-threading off and eliminates all errors caused by the feature.

Using this parameter is highly recommended in all applications where speed is a critical factor.

9 Reference

9.1 Data Types

If Node parameter Address_Type is set as ADU or PDU, then Data_Type must be specified as follows.

Address_Type ADU:

Address range	Data_Type	Function Code (Write)	Function Code (Read)
1 – 65536	Coil	15	1
1 – 65536	Discrete_Input	n/a.	2
1 – 65536	Input_Register	n/a.	4
1 – 65536	Holding_Register	16	3

Address_Type PDU:

Address range	Data_Type	Function Code (Write)	Function Code (Read)
0 – 65535	FC01	15	1
0 – 65535	FC02	n/a.	2
0 – 65535	FC04	n/a.	4
0 – 65535	FC03	16	3

Address_Type Modicon_5digit:

When a Modbus address range is specified, a particular Data Type is implied (defaults shown below).

Address range	Data_Type	Function Code (Write)	Function Code (Read)
00001 – 09999	Coil	5,15	1
10001 – 19999	Discrete_Input	n/a.	2
30001 – 39999	Input_Register	n/a.	4
40001 – 49999	Holding_Register	6,16	3

9.2 Single Writes

If writing multiple registers, the write function will 16.

If writing multiple coils, the write function will 15.

If writing a single register, the write function will be 6 unless Write_FNC parameter is set to “Multiple”.

If writing a single coil, the write function will be 5 unless Write_FNC parameter is set to “Multiple”.

9.3 Driver Error Messages

Message	Description/Action
MB_TCP:#01 FYI. Server response extra bytes ignored. Cnt=%d %#x	This message is printed when the TCP frame contains more bytes than a single Modbus_TCP message but insufficient extra bytes to form a second complete Modbus message. There is no explanation for the 'padding' bytes, but since the Driver ignores the extra bytes and processes the complete message correctly, the message can be ignored. The driver prints this message once. It is suppressed on subsequent occurrences.
MB_TCP:#02 FYI. Master poll extra bytes ignored. Cnt=%d %#x	
MB_TCP:#03 Err. TCP Frame has multiple MB_TCP messages. Ignored 2nd	The driver has detected enough bytes in the TCP frame for two complete Modbus_TCP messages. The second message is ignored. If this is a problem, re-configure the remote node so that only one Modbus_TCP message is contained in a single TCP frame. The driver prints this message once. It is suppressed on subsequent occurrences.